

Material number	0 611 338 7F0
EAN	4059952513775
1 x pointed chisel, SDS max, 280 mm	✓
1 618 600 023	
Auxiliary handle	✓
1 619 P14 935	
Carrying case	✓



Technical data

Description

Long version part 1 (BE)

The new GSH 500 Professional demolition hammer is perfect for breaking and chiselling in concrete, stone, rock, and brickwork. It delivers great power coupled with a superior impact rate to offer high chipping output. Its large hammer pipe and improved impact system design makes the tool more effective during chiselling work. Meanwhile, the tool is equipped with a grease sealing ring to prevent leakage and a dust cap solution to make it dustproof. It also offers one-hand Vario-Lock design for 12 chisel bit position changing which helps you to work comfortably from any position.

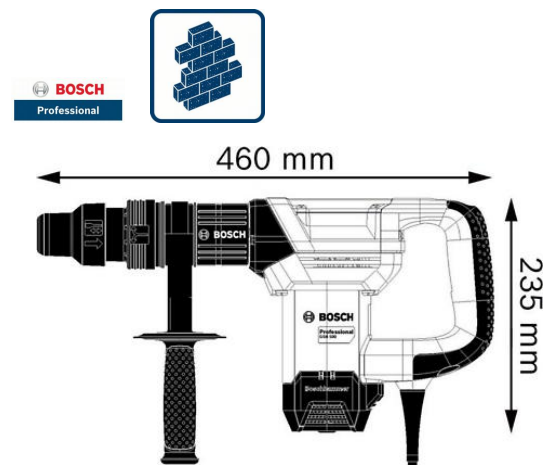

Noise level	The A-rated noise level of the power tool is typically as follows: Sound pressure level dB(A); Sound power level dB(A). Uncertainty K= dB.
-------------	--

Technical data

Rated input power	1.100 W
Impact energy (according to EPTA 05/2016)	7.8 J
Impact rate at rated speed	2,900 bpm
Weight	5,7 kg
Tool dimensions (width)	103 mm
Tool dimensions (length)	460 mm
Tool dimensions (height)	235 mm
Tool holder	SDS max

Sales information

Positioning

- Fast & Reliable - The NEW Chipping Specialist!

User benefit

- Great efficiency: High impact energy coupled with superior impact rate resulting in high chipping output
- Extended durability: Grease sealing ring to prevent leakage coupled with dust cap solution for better dust proof resulting long life time
- Ergonomic design: One hand Vario Lock design for 12 position chisel bit change, lock-on button for daily continuous work